

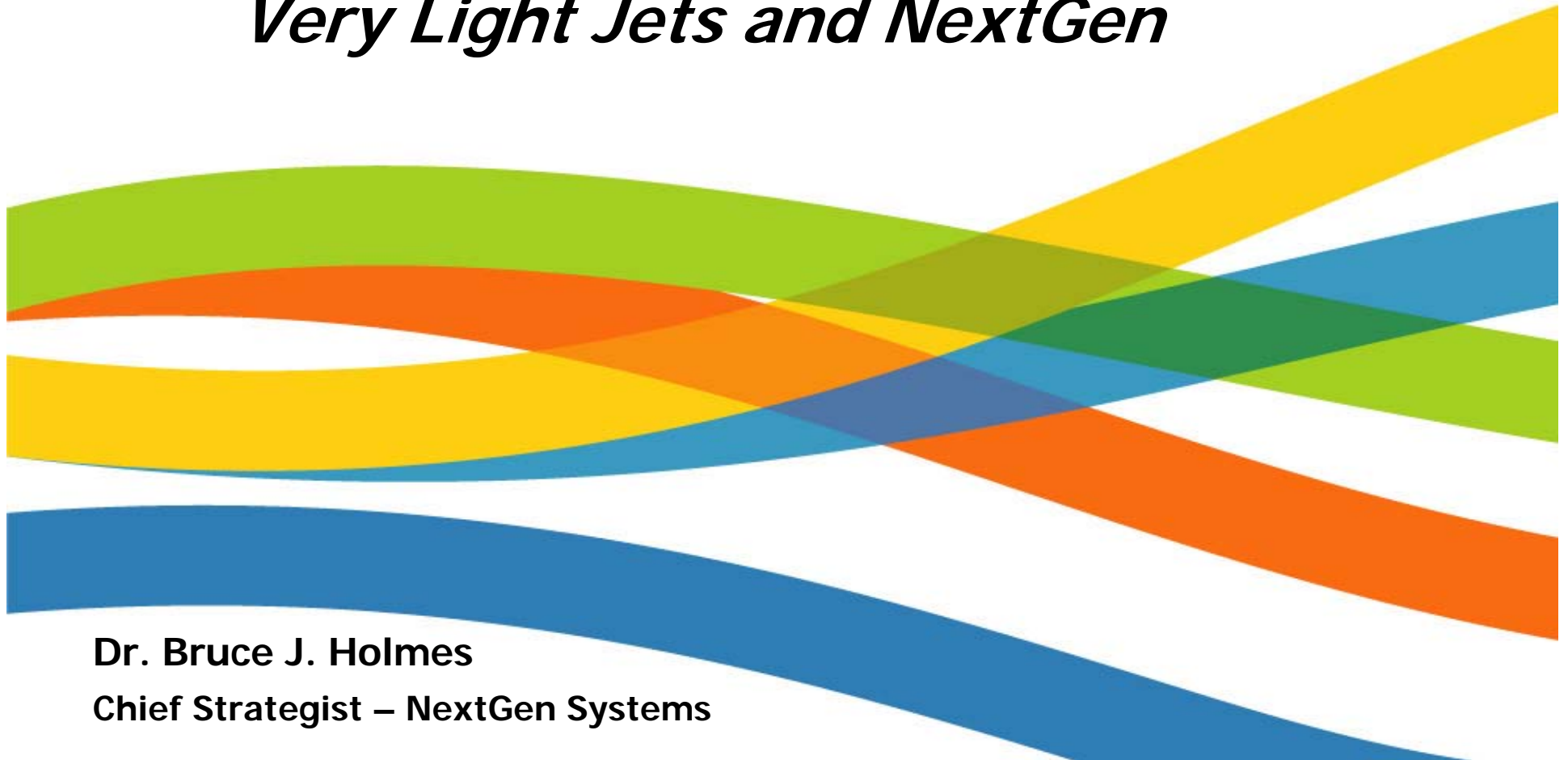

Innovation in Aviation: Very Light Jets and NextGen



Dr. Bruce J. Holmes
Chief Strategist – NextGen Systems

Topics



- **The DayJet Story**
- **Context for Innovation in Aviation**
- **Accelerating NextGen**





DayJet (born on October 3, 2007)



The World's First DayPorts



May 2008

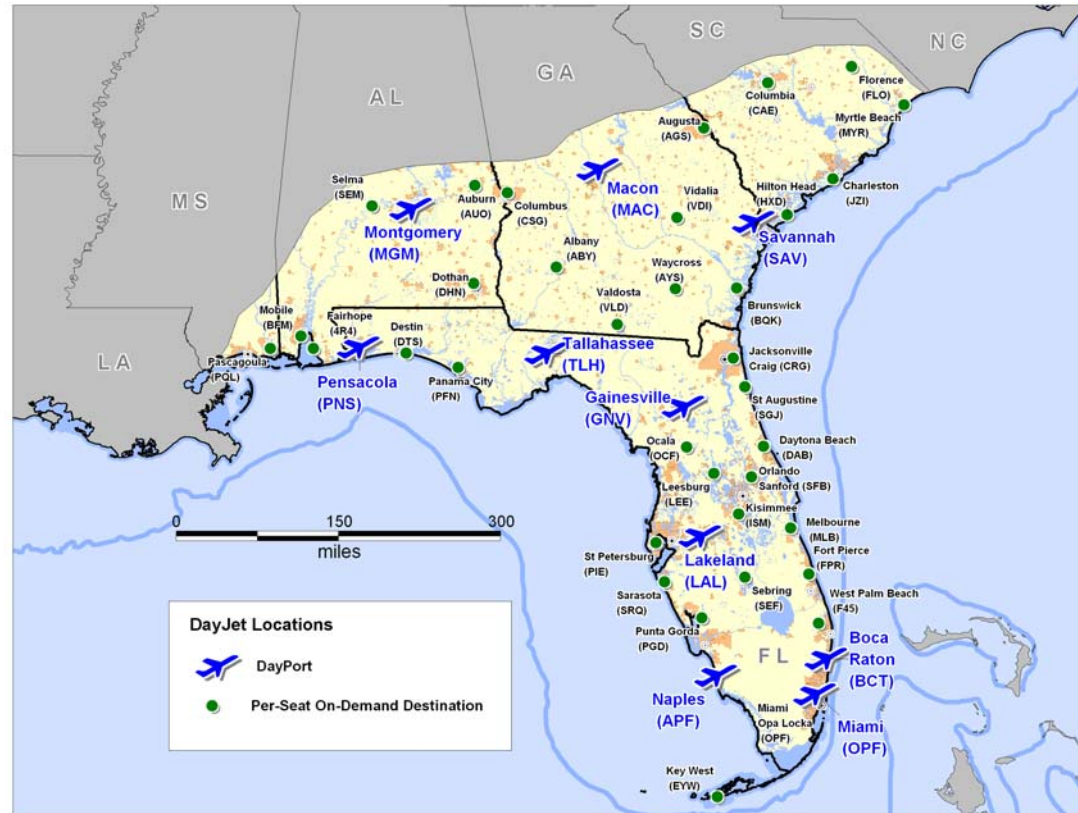

September 14, 2007





A Service Innovation: Per-Seat On-Demand



“Per-Seat, On-Demand”



Defining Characteristics

- **Per-Seat** A “shared ride” service sold by the individual seat, with advance reservations. Pay only for the seats required, not the whole plane.
- **On-Demand** Operates on no one else’s schedule but yours. Gives you the freedom to travel where you want, when you want.
- **Direct** Flies point-to-point to/from small community airports, and does not fly into major hub airports.
- **Affordable** Modest premium to equivalent regional full-fare coach airfare.

The Enablers



A new market enabled by new technologies...



+



(1) Large fleets of new-generation, cost-effective, easy-to-operate, ecologically friendly VLJ aircraft

(2) A new generation of proprietary, fully integrated, real-time logistics, optimization & operations systems

Context for Innovation In Aviation

National and Technological



The Hub-and-Spoke Challenge

FAA: Capacity Needs in the National Airspace System. 2007



2015

Planned additional capacity leaves six airports and four metropolitan areas that **need additional capacity**.

Figure 2
Airports and Metropolitan Areas Needing Additional Capacity in 2015 after Planned Improvements

- 6 airports that need additional capacity in 2015
- 4 metro areas that need additional capacity in 2015



Notional Life Cycles in Transportation

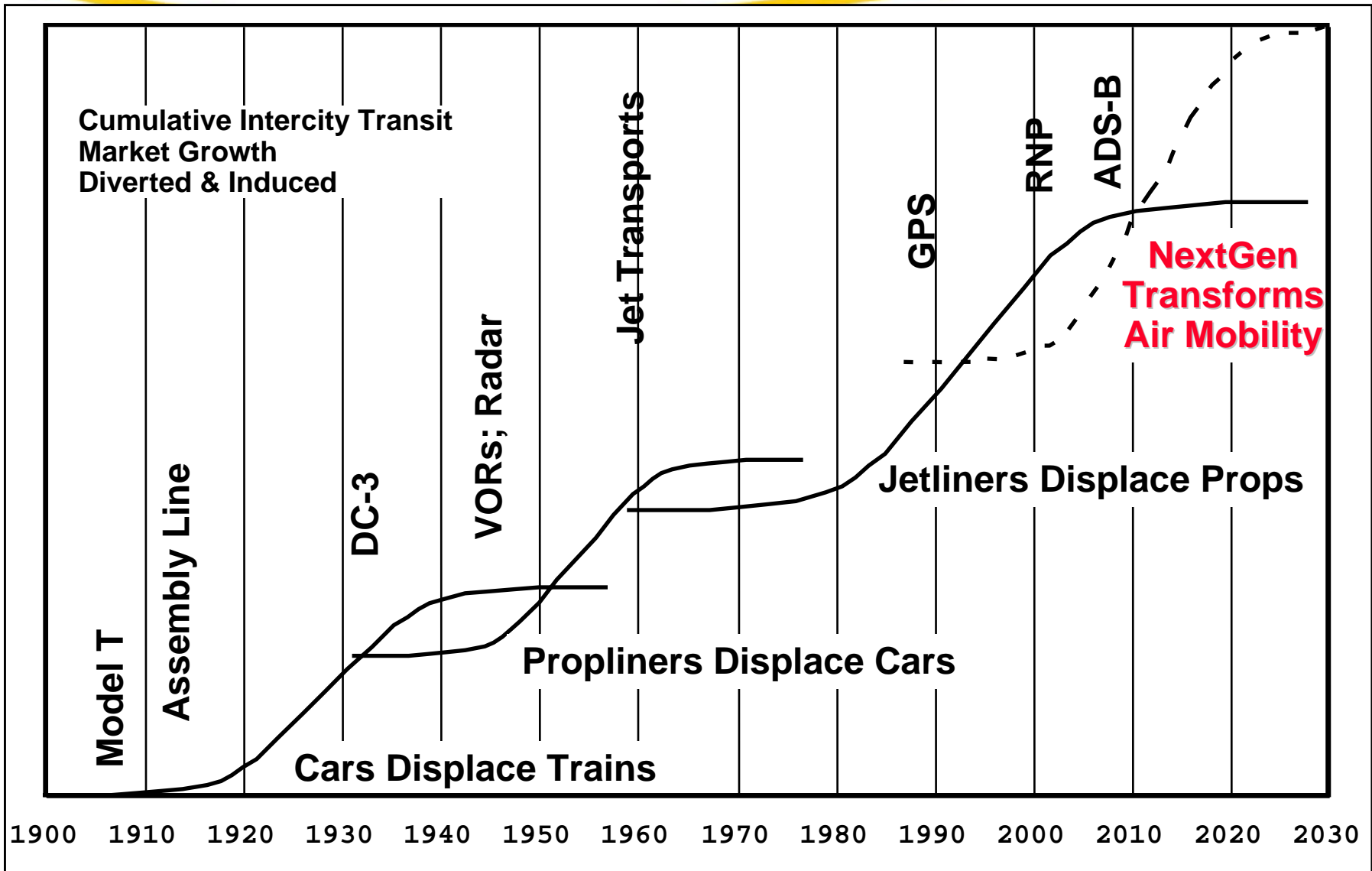

The Interstate Highway Challenge

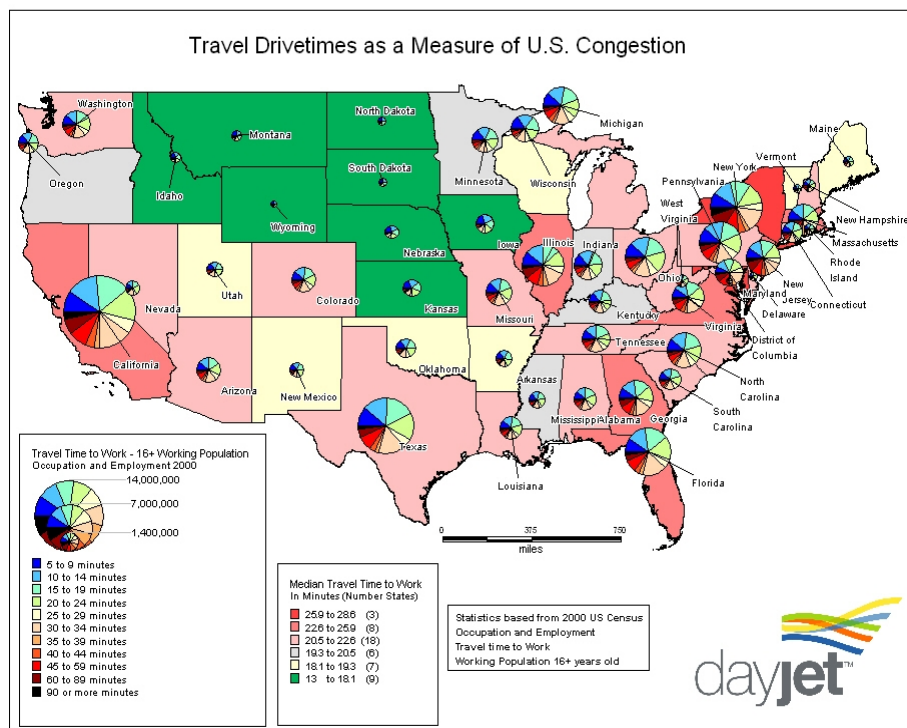

- For 30 states, road congestion is a serious issue for more than 1/3rd of the population.

The Hub-and-Spoke Challenge

FAA: Capacity Needs in the National Airspace System. 2007



2015

Planned additional capacity leaves six airports and four metropolitan areas that **need additional capacity.**



Solutions include integrated airspace operations between Metroplex areas.

Serving the Long Tail

An ecology of business models is required

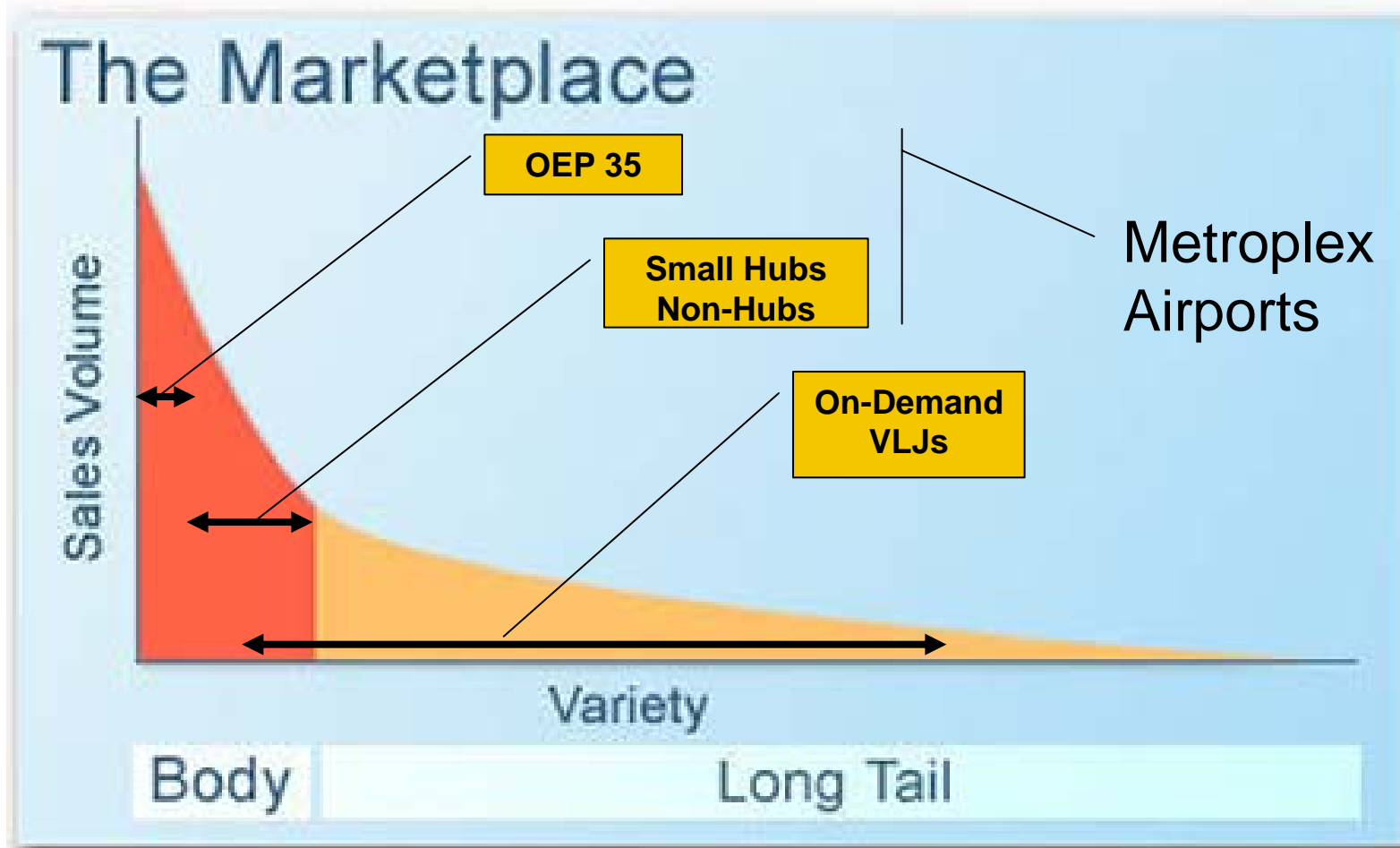

The Long Tail: Why the Future of Business is Selling Less of More
Chris Anderson



NextGen Demonstration

To accelerate the early adoption of certain operating capabilities envisioned in the NextGen Concept of Operations

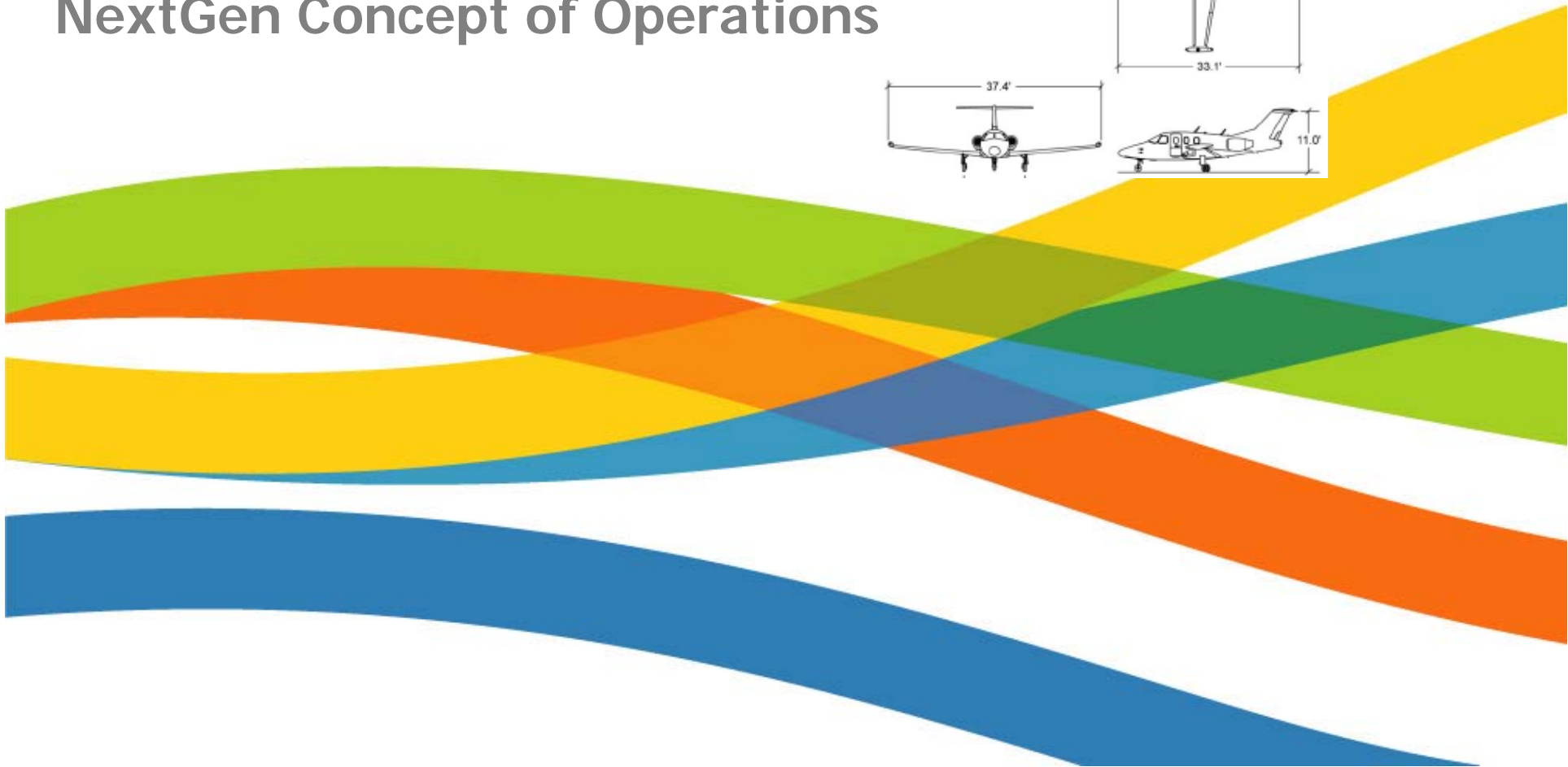
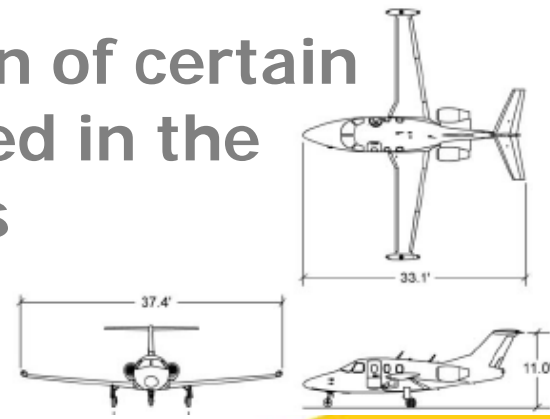

Accelerating growth



NextGen Technologies

- Required Navigation Performance (RNP)
- ADS-B
- Digital Communications

Operating Capabilities

- RNAV Routes
- RNP Departures, Arrivals, Approaches
- Merging, Spacing, Passing

Benefits

- Footprint (Energy, Carbon, Noise)
- Airspace expansion
- Economic Development Opportunities

Infrastructure

Enabling Capabilities



NextGen Avionics

RNAV / WAAS

RNP 0.3

LPV / SAAAR

Auto throttle

ADS-B in / out

Airborne Networking

Spacing Assurance

Airborne Merging

Machine Vision



... and more in the future

Airports and Airspace Infrastructure

Enabling Capabilities



- **State Aviation System & Airport Master Planning for NextGen**
- **Tailored departure and arrival flight paths**
- **Tracking of all traffic on the ground and in the air**
- **Precision minimums for all runway ends**
- **Remote Tower Services**
- **Alternatives for approach lighting**
- **Digital weather information, Notams**



... and more in the future

Demo Outcomes



- **Acceleration** by early adopters
- Reduced **cost** for increased airspace capacity
- Reduced **footprint**



Summary



The Story of Life Cycles

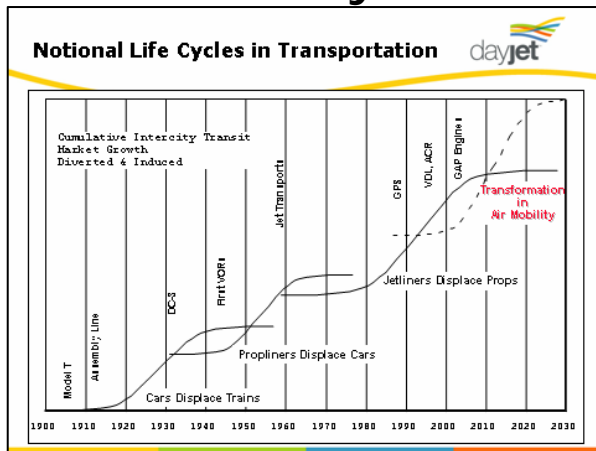

The Story of the Long Tail

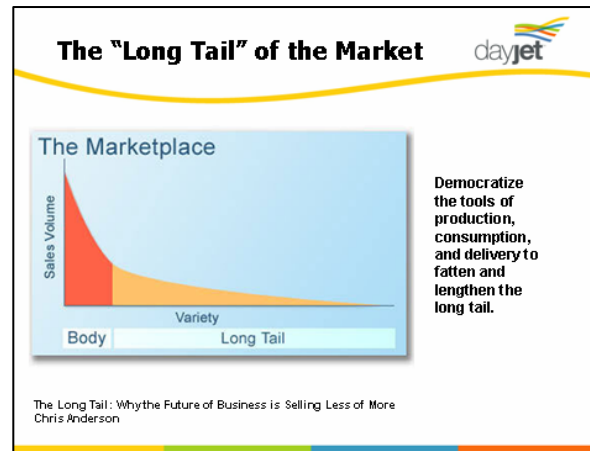

Accelerating NextGen

Infrastructure
Enabling Capabilities

- NextGen Avionics
- RNAV / WAAS
- FMS
- RNP
- LPV / SAAAR
- Auto throttle
- ADS-B in / out
- Airborne Networking
- Spacing Assurance
- Airborne Merging
- Machine Vision



... and more in the future

The ingredients for foundational innovation in air transportation

Thank you!
www.dayjet.com



Seize the Day