

# **Onboard IVHM Communications Requirements for Commercial Transport Aircraft**

**ICNS Conference**

**May 6, 2008**

**Jim Griner  
NASA John H. Glenn Research Center  
(216)433-5787  
jgriner@nasa.gov**



# IVHM Future Concept of Operations

Aviation Safety Program

IVHM

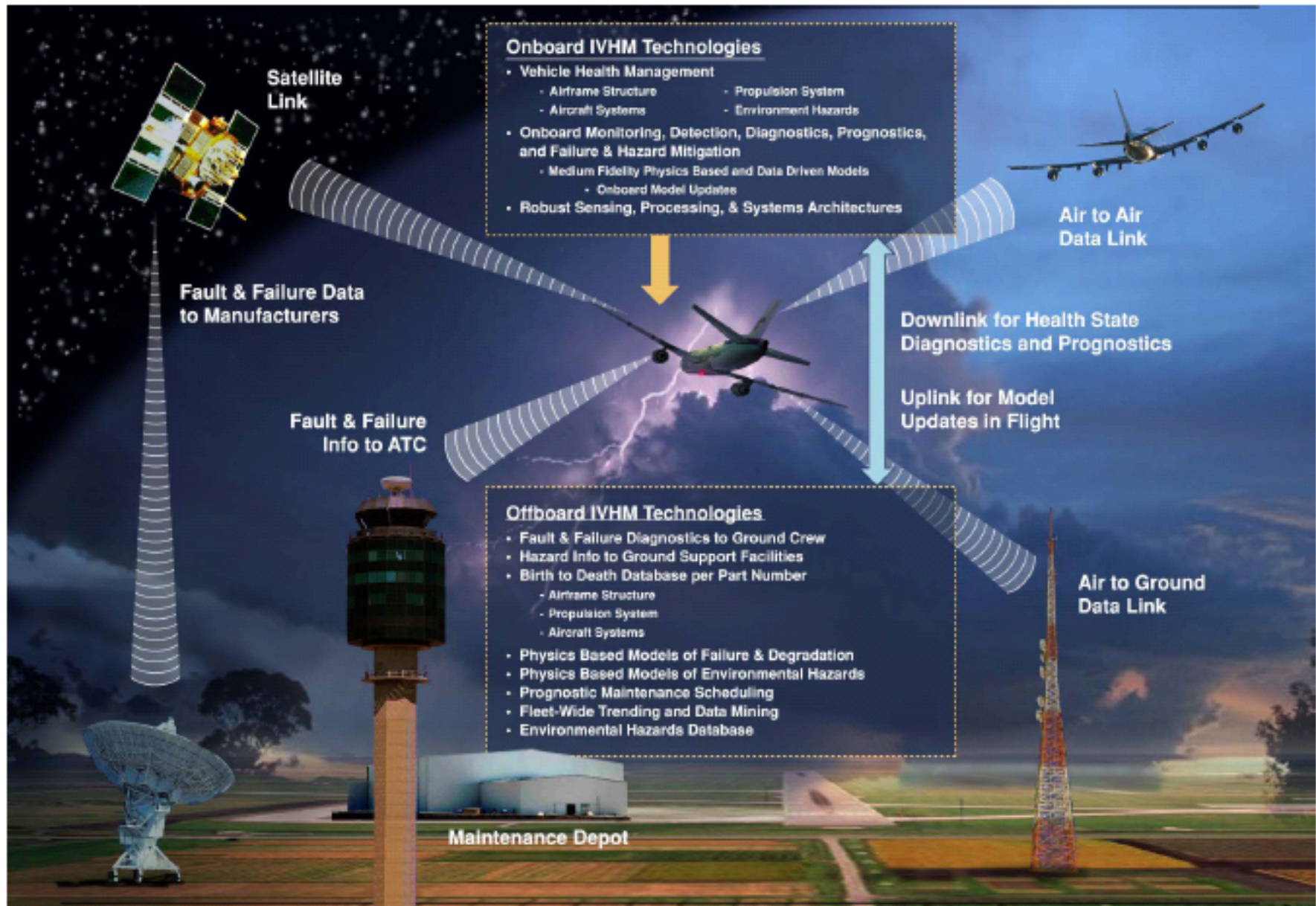

- Provide continuous on-board situational awareness of vehicle health state for use by the flight crew, ground crew, and maintenance depot
- Reduce system and component failures as causal and contributing factors in aircraft accidents and incidents



# IVHM Communication Needs

*Aviation Safety Program*

*IVHM*

- Connection of all sensing and processing elements
  - Airborne and Ground Based
- Operation throughout airframe environment
  - Harsh Environments (Temperature, Vibration, EMI, etc.)
  - Constrained Spaces (enclosed metal/composite structures)
- Robust
  - Must function during off-nominal conditions



# Onboard Requirements Approach

*Aviation Safety Program*

*IVHM*

- Determine current sensor locations, data precision, and data rates for a typical commercial transport aircraft
- Determine future sensor locations, data precision, and data rates from sensor and algorithm developers
- Determine communications necessary to sensors, for calibration, data rate “throttling,” etc.
- Make tradeoffs considering: data rates, network architectures, transmit power, and data processing within the sensor



# Goal

*Aviation Safety Program*

*IVHM*

- Develop requirements which can be used across all commercial transport aircraft
  - Boeing 757-200 selected as current example
- Ability to scale requirements accordingly based on size of aircraft



# Functional Requirements

*Aviation Safety Program*

*IVHM*

Ability to transmit/receive data from all defined sensors and processing elements.

- The predicted number of sensors was determined, given the sensor type, spatial density, and expected location, based upon the dimensions of a Boeing 757-200.
  - Structural monitoring
  - Ice monitoring
  - Performance and health of engines
  - Pressure sensing and gas presence
  - Fire detection
- The predicted data volume was determined based on number of sensors, data (number of data bits), and the frequency of transmission.

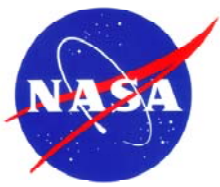

# Numbers of Sensors

Aviation Safety Program

IVHM

## Calculation example detail

<i>Sensor Type</i>	<i>Sensor Density</i>	<i>Aircraft Location</i>	<i>Respective Dimension (757-200)</i>	<i>Predicted Number of Sensors</i>
<i>Structural/Avionics Health Management</i>				
Corrosion and Cracking	3/m <sup>2</sup>	Surface of wings	181 m <sup>2</sup>	543
Landing Gear	2/wheel	Landing Gear	10 wheels	20
EMI	1/50 m <sup>2</sup>	Surface area of aircraft	736 m <sup>2</sup> (a)	15

### Summary

- Structural/Avionics (2388)
- Icing (228)
- Propulsion (234)
- Pressure (20)
- Gas (321)
- Fire (576)



# 757-200 General Fuselage Sensor Locations

Aviation Safety Program

IVHM

1	Structural
2	Ice
3	Propulsive
4	Pressure
5	Gaseous
6	Fire
7	EMI

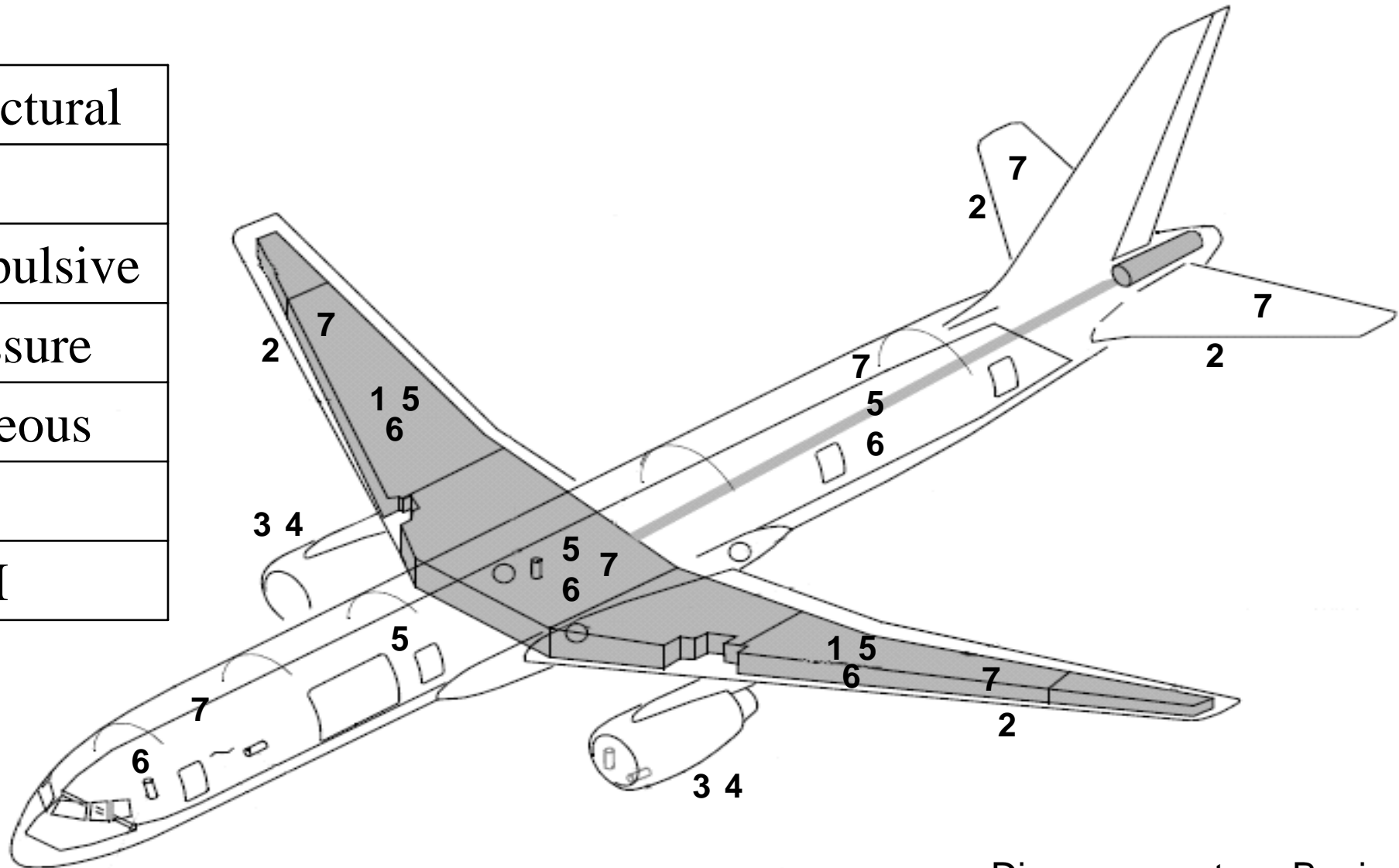

Diagram courtesy Boeing



# General Engine Sensor Locations

Aviation Safety Program

IVHM

## Pratt & Whitney PW2000

1	Structural
2	Ice
3	Propulsive
4	Pressure
5	Gaseous
6	Fire
7	EMI

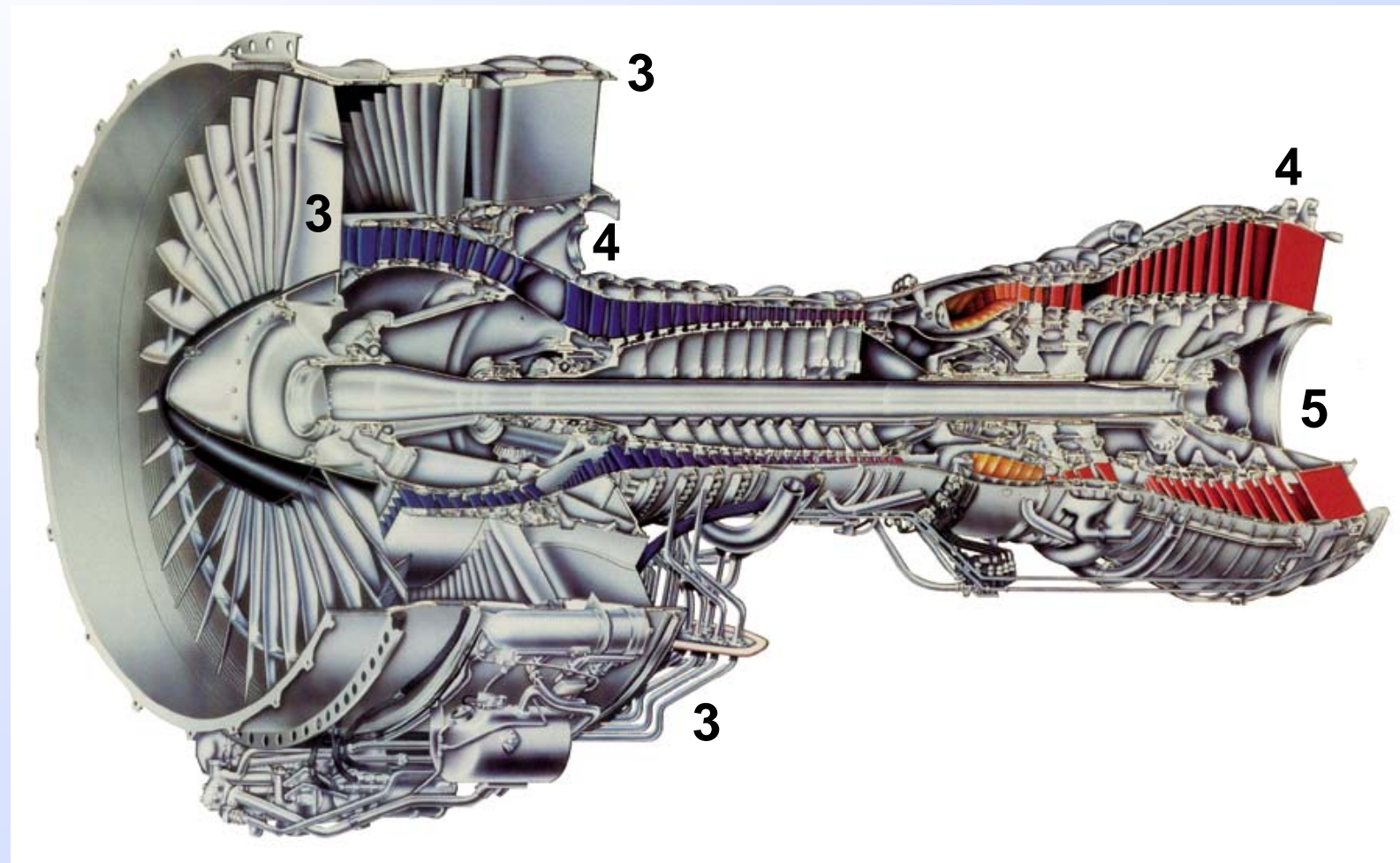
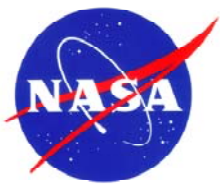

Diagram courtesy  
Pratt & Whitney



# Predicted Data Rates

Aviation Safety Program

IVHM

## Calculation example detail

<i>Sensor Type</i>	<i>Predicted Number of Sensors</i>	<i>Number of data bits per transmission</i>	<i>Frequency of Transmission (Hz)</i>	<i>Data Rate per Sensor (bits/sec)</i>
<i>Structural/Avionics Health Management</i>				
Corrosion and Cracking	543	4	100	400
Landing Gear	20	20	200	4000
EMI	15	8	100	800

Structural/Avionics Total:  
3Mbps



# Measures of Performance

*Aviation Safety Program*

*IVHM*

- Device Failures
- Communication Disruption
- Communication Restoration
- Communication Re-routing
- Device Isolation



# Modes of Operation

*Aviation Safety Program*

*IVHM*

- Configuration
- Calibration
- Test
- Operational



# Measure of Effectiveness

*Aviation Safety Program*

*IVHM*

- Maintainability
- Usability
- Reliability
- Safety
- Risk to Structure
- Risk of Fire
- Risk of EMI
- Cost



# Design Characteristics

*Aviation Safety Program*

*IVHM*

- Weight
- Size
- Power
- Durability
- Maintainability
- Accessibility
- Location



# Future Work

*Aviation Safety Program*

*IVHM*

Onboard Wireless Communication Architectures

Offboard Communication Requirements