

Broadband Data Communications using Energy-Efficient White LEDs on Aircraft Power-lines

Prof. M. Kavehrad (FIEEE), Z. Hajjarian and A. Enteshari

Department of Electrical Engineering,
Center for Information and Communications Technology Research
The Pennsylvania State University,
University Park, PA, 16803

Power-line Communication (PLC)

- **Pros**
 - Utilizes an already installed power grid for data transmission to and from on-board sensors.
 - Can achieve a fairly reasonable throughput.
- **Cons:**
 - Electromagnetic interference (EMI) into/from other networks. However, this can be resolved by spectrum management and proper countermeasure designs.
 - Requires full characterization of channel impulse response.
 - Requires identification of inherent and possible interfering noise sources.
 - Two key parameters, insertion loss and return loss, are time varying, as load on the lines changes.

Power line Characteristics

- Power lines were not designed for broadband communications, thus represent a harsh environment.
- Critical factors are;
 - Noise
 - Channel transfer character.
 - Impedance* mismatches due to time varying impedances as a consequence of time varying load.
- Each power-line acts as a **BUS**; the available band has to be shared by user nodes.
- Wires made of aluminum with a conductivity 61% of standard annealed copper.
- Wires are **unshielded**: Quasi-Guided (**Guided + Unguided**) Modes exist.

* Power line impedance is determined by devices plugged into the line and the number of branches.

Some information on power lines

Impedance mismatch (discontinuity) causes reflection in lines, creating a multi-path response

$$r = |\rho| = \left| \frac{Z_{load} - Z_{line}}{Z_{load} + Z_{line}} \right| = \text{Voltage reflection coefficient}$$

$$t = 1 - r$$

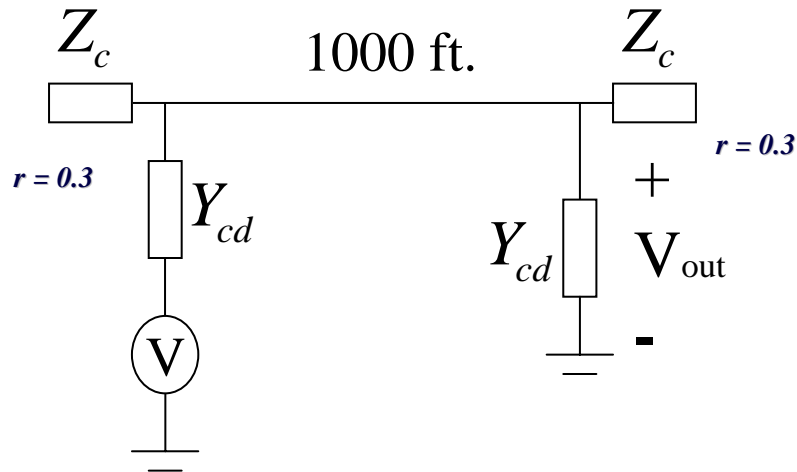

*Point-to-point line with mismatch:
 Reflection coefficient = r*

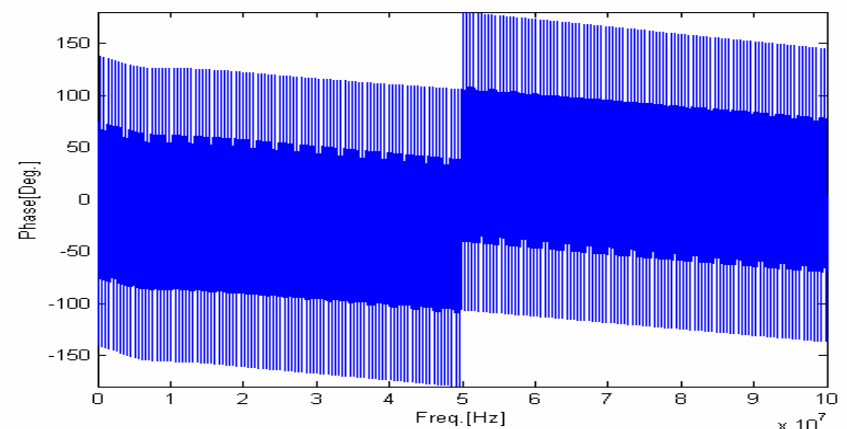
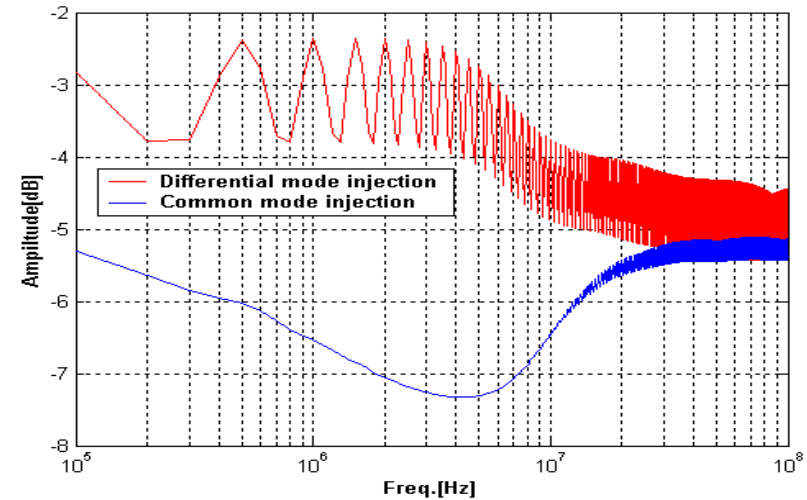

Amplitude and Phase Transfer function for point-to-point line, differential injection $r = 0.3$

Measured Noise in Korea

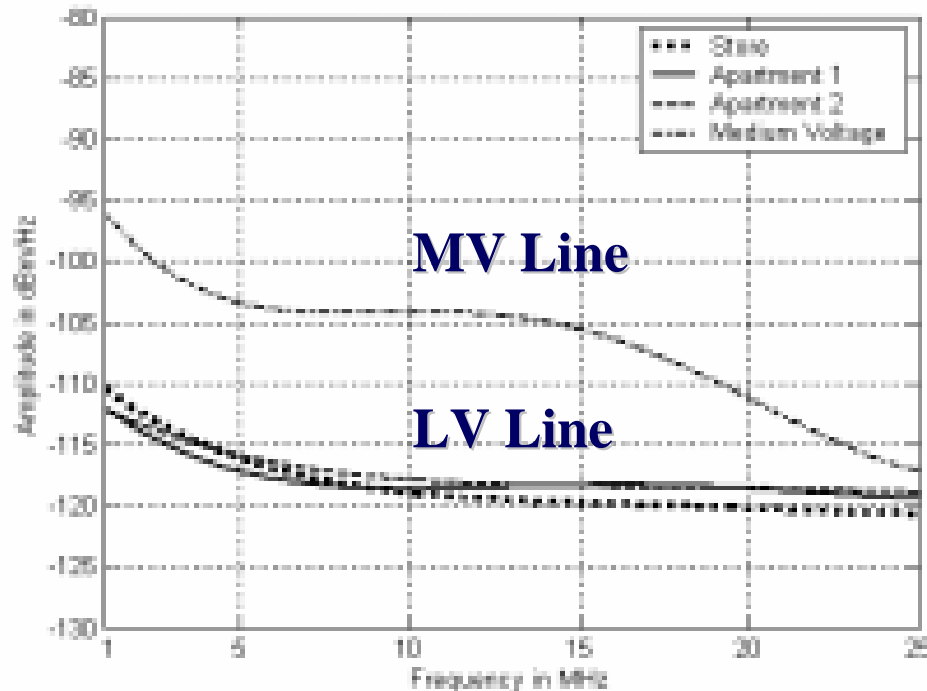

*Assumed noise level in
 capacity estimations
 -117 dBm/Hz*

**Comparison of noise levels between medium voltage (MV)
 power lines and low voltage (LV) subscribers**

† J. Lee, et al, "Measurements of the Communications Environment in Medium Voltage Power Distribution Lines for Wide-Band Power Line Communications," ISPLC 2004.

Sample Measurements Results

- At Edwards AFB in California, the +28Vdc aircraft power-lines were characterized for data transmission. Transmission band of 10 MHz to 100 MHz on the lines were tested.

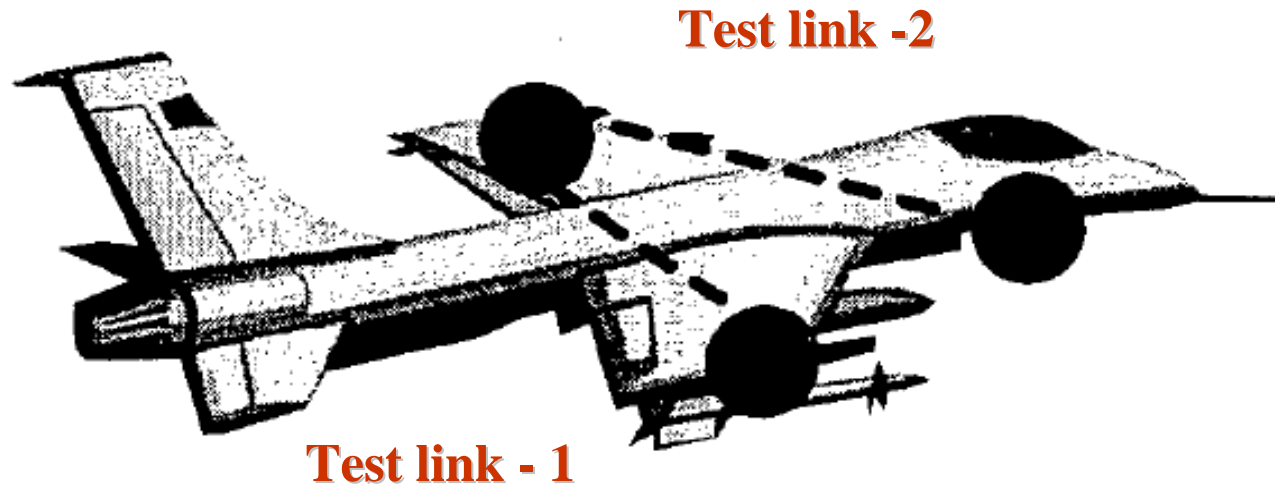

- **Test Link-1** from Left Wing to Right Wing
- **Test Link-2** from Left Wing to Right Side Under Cockpit

Problems with the Bus Structure

The bus structure makes high-speed data transmission difficult for two reasons:

- A data transmission path between two devices will see many various-length stubs. Every other device on that bus is wired to the single circuit breaker controlling that bus and from that common point power to all other devices on that bus originates. Even at moderate RF frequencies, each stub looks like a short circuit to ground at some frequency.
- Since there is no return line, characteristic impedance of a single line is poorly controlled.
- If the return had a dedicated wire and it ran in proximity to the power line, characteristic impedance would be at least mildly controlled.

Test Link-1 Channel Capacity

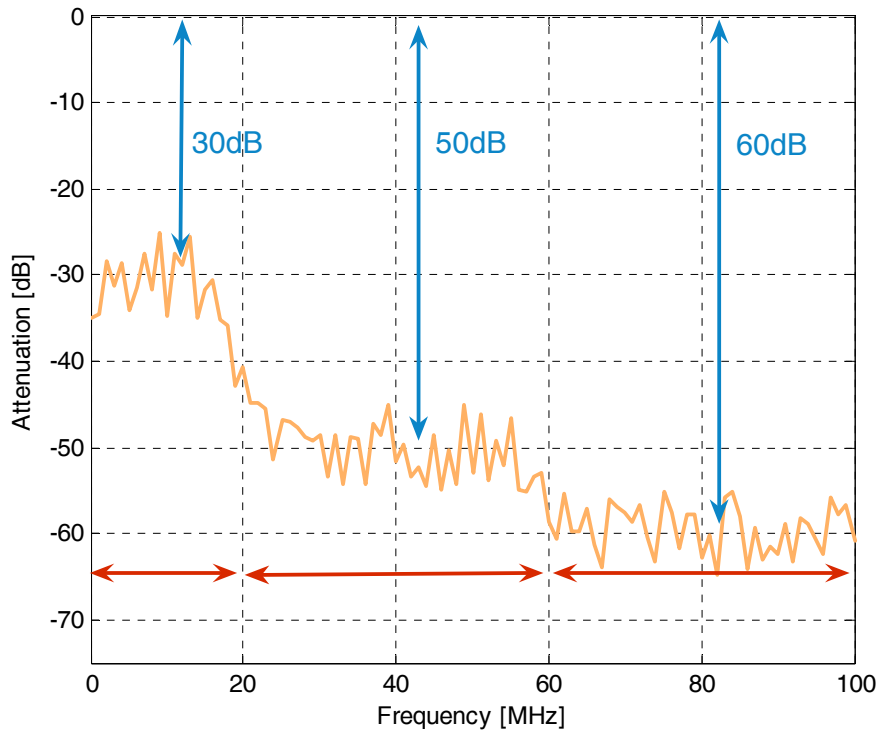

Forward Transfer Function of Test Link-1 from Left Wing to Right Wing

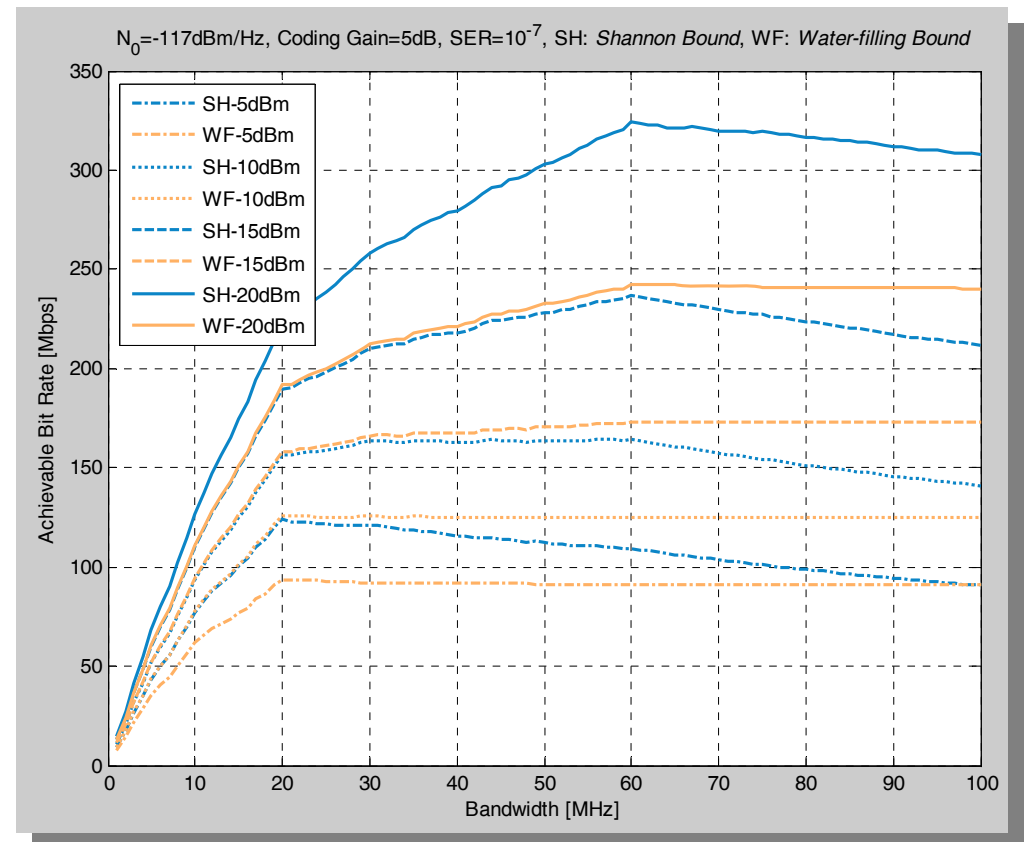

Maximum achievable bit rate for different transmit launched power levels

Intensity Modulation/ Direct Detection

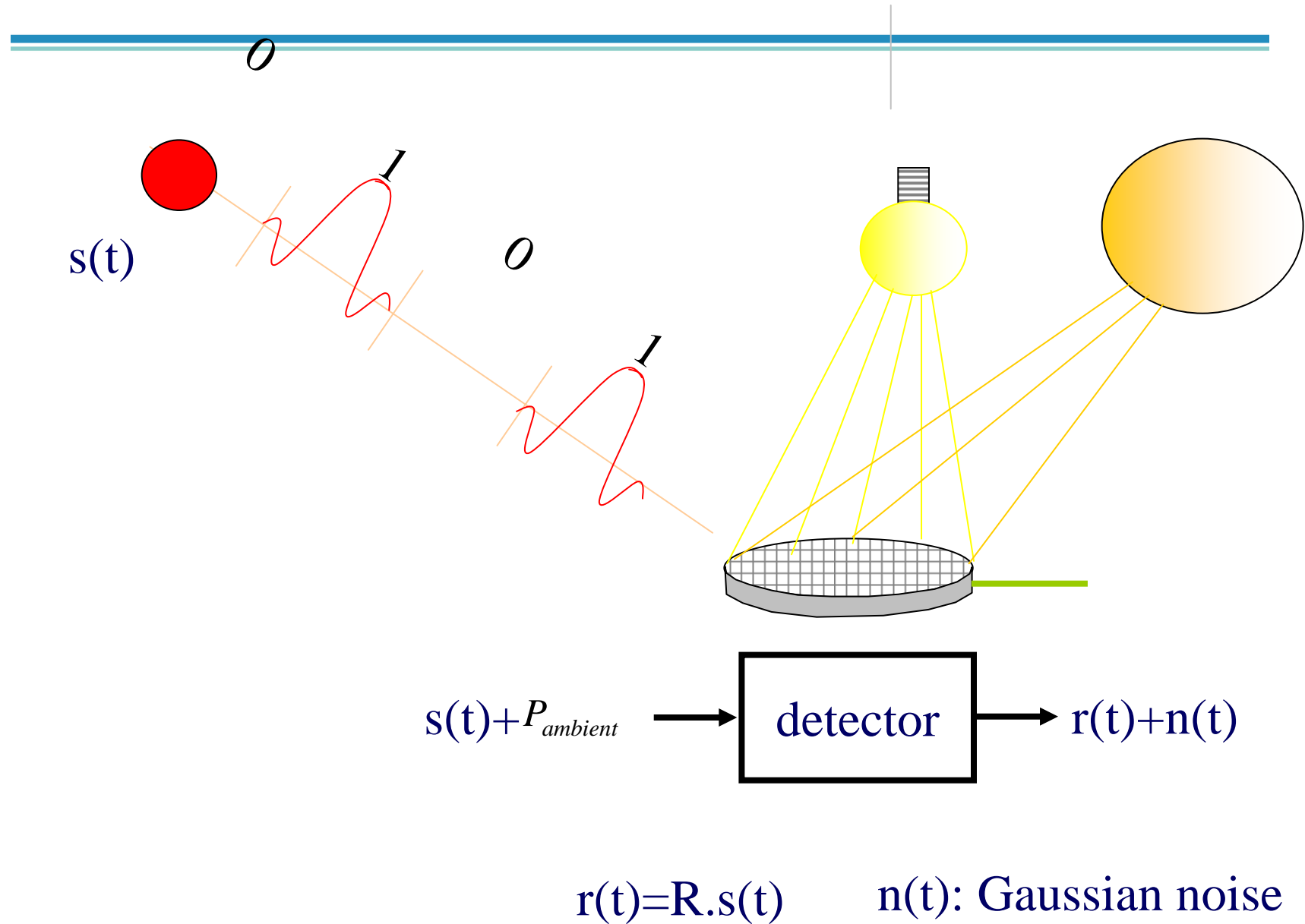

Ambient Light

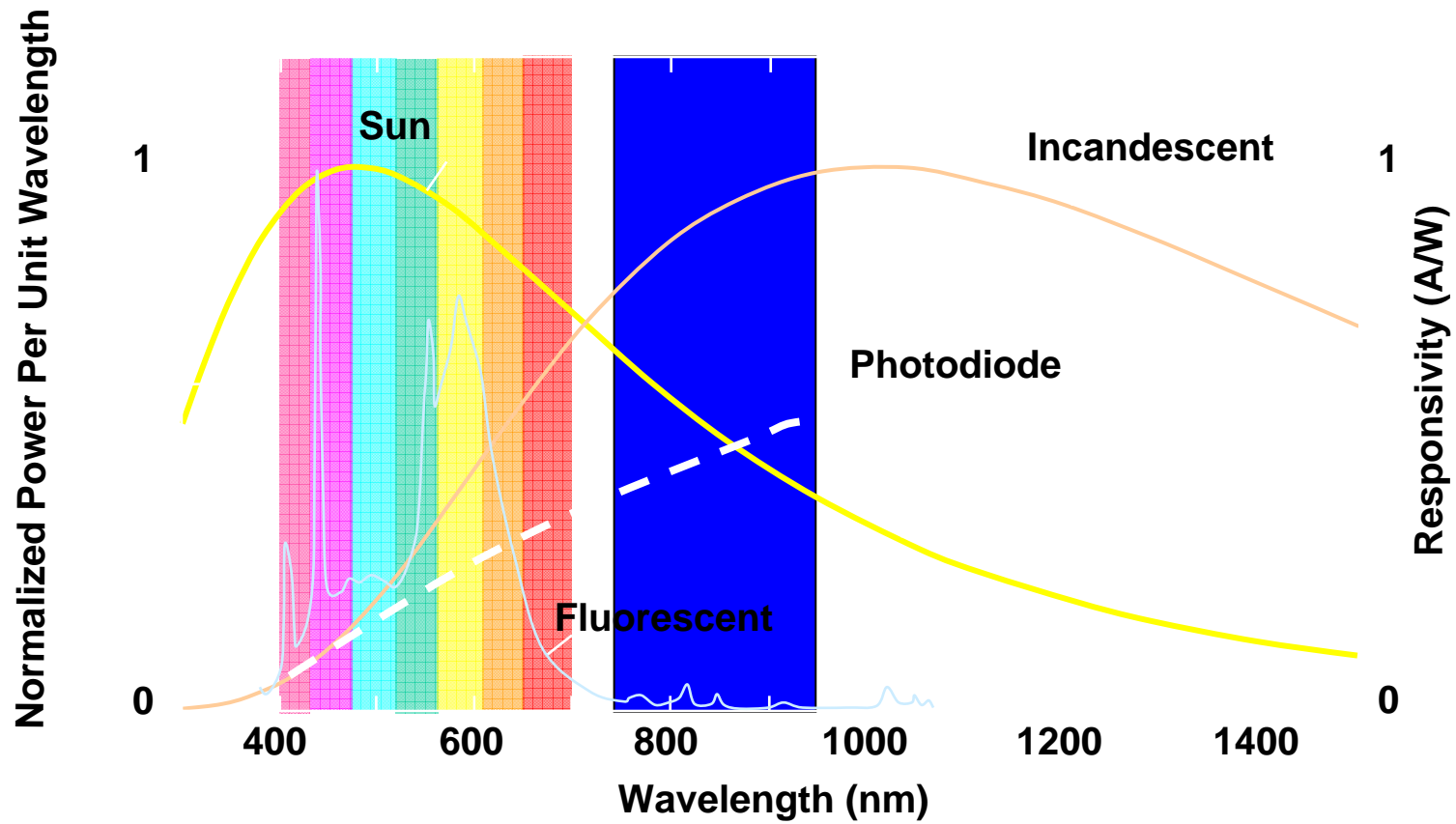

White Light Emitting Diodes (W-LED)

- Bright output, high power efficiency, long life-time (30,000 hours)
- Faster photo-response than fluorescent light
- Resistance to humidity and shadowing
- Low power consumption (25 lm/W), minimal heat generation
- Easy to install, aesthetically pleasing unlike fluorescent light
- More rugged (no filament or glass envelope to break)



Single-Chip WLED

- Single-chip: YAG(Yttrium Aluminum Garnet) phosphor coated InGaN-based blue LED.
 - Low cost, bright output.
 - Lower response speed compared to multi-chip-type WLED.
 - Deficient in color rendering output.

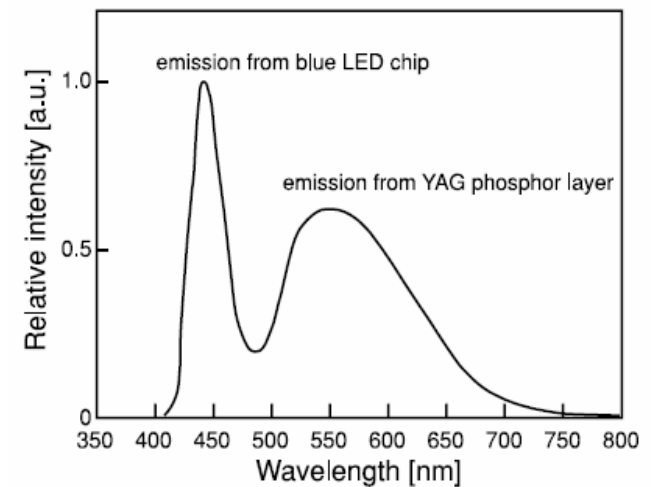
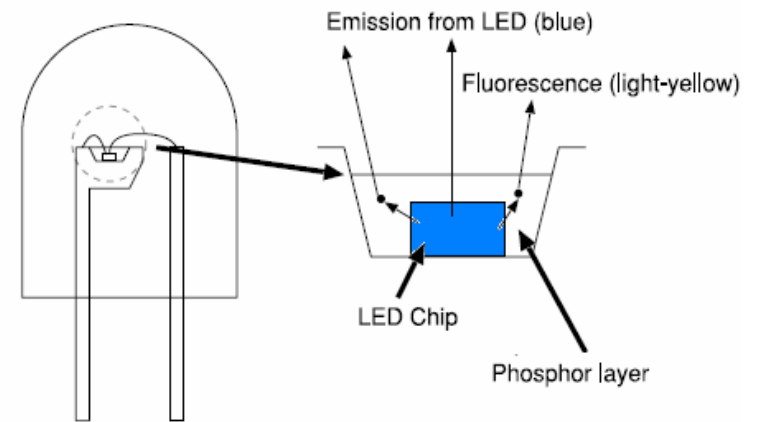

One-chip-type white LEDs.
(InGaN blue LED chip and YAG phosphor)

Multi-Chip WLED

- Multi-chip: mixes the light from LEDs of three primary colors.
 - changing the mixture ratio of three primary colors → different colors.
 - It is hard to simultaneously modulate three LEDs.
 - Using LEDs of different colors for different users and exploit this multi-chip property for multiplexing.

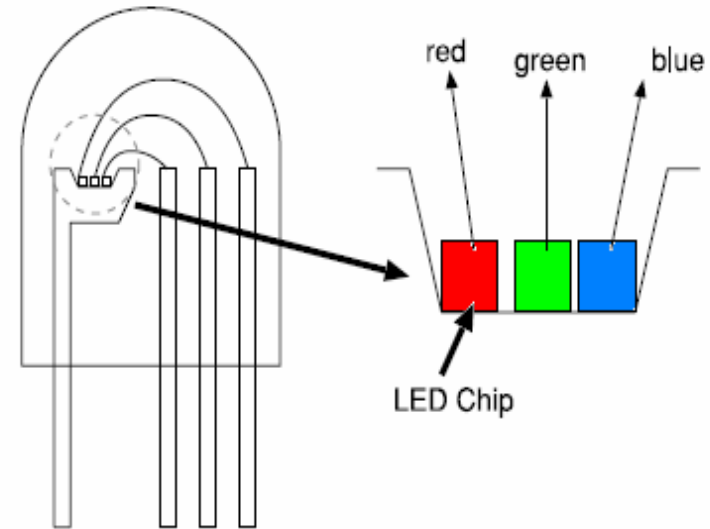

Combination of three primary colors with same tone ($x = 0.31$, $y = 0.33$) and its mixture ratio.

	red	green	blue	efficiency (lm/W)	
I	wavelength (nm)	600	555	480	291
	mixture ratio	1	0.89	2.51	
II	wavelength (nm)	610	555	475	317
	mixture ratio	1	1.43	2.29	
III	wavelength (nm)	610	555	450	391
	mixture ratio	1	2.62	1.96	
IV	wavelength (nm)	610	565	450	413
	mixture ratio	1	11.17	7.19	

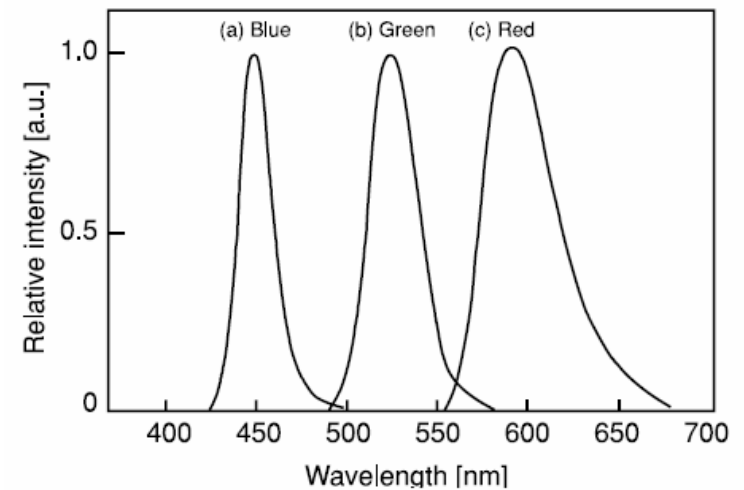

Multi-chip-type white LEDs.
 (InGaN blue + AlInGaP green + AlGaAs red)

Link Budget Calculation cont.

- SNR for OOK modulation is given by:

$$BER = Q(\sqrt{SNR}).$$

- Setting a target bit error rate at (10^{-6}), the required SNR is 22.6 or 13.54 dB.
- Given this target BER, figure below shows the required received power at different background noise current levels. Hence, a bit rate of 1 Gbps is easily achievable.

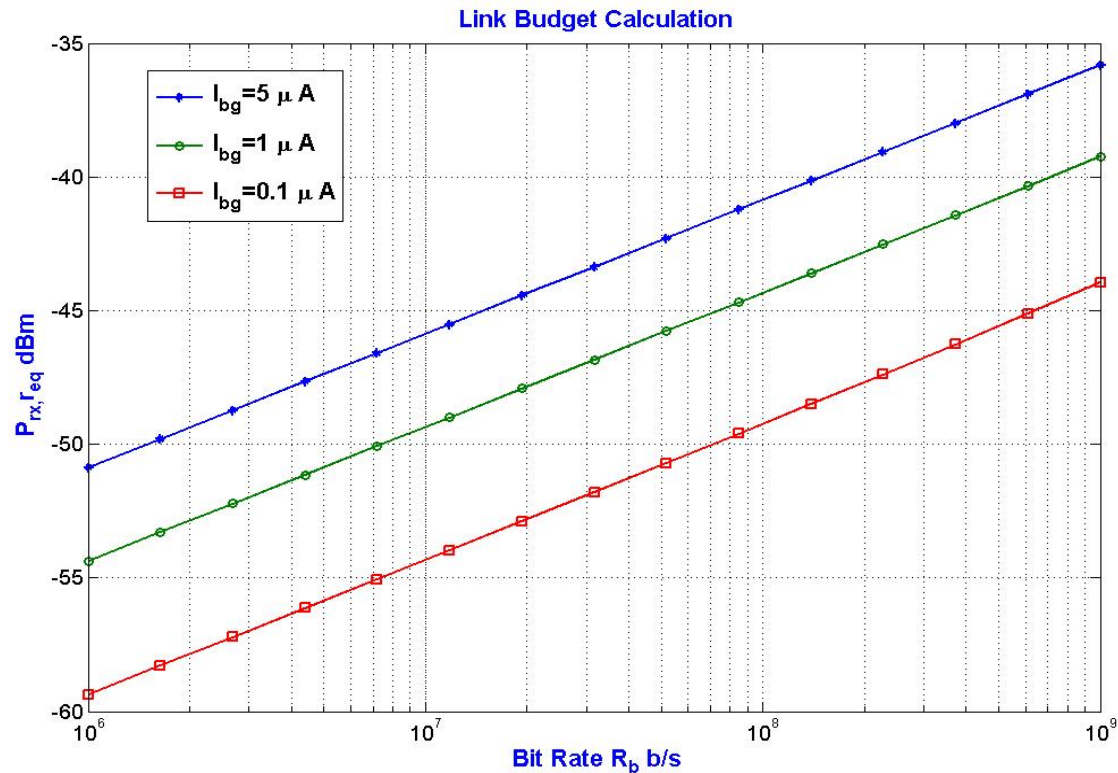

Micro-Cell Configuration

- *Seat pitch* is the distance between the seat rows. Typically, 31-32 inches in economy class.
- *Seat width* is the distance from armrest to armrest, in Economy class this is typically around 17 inches.
- Cabin height
 - Typically: 3.70 m (12 ft 1 in).

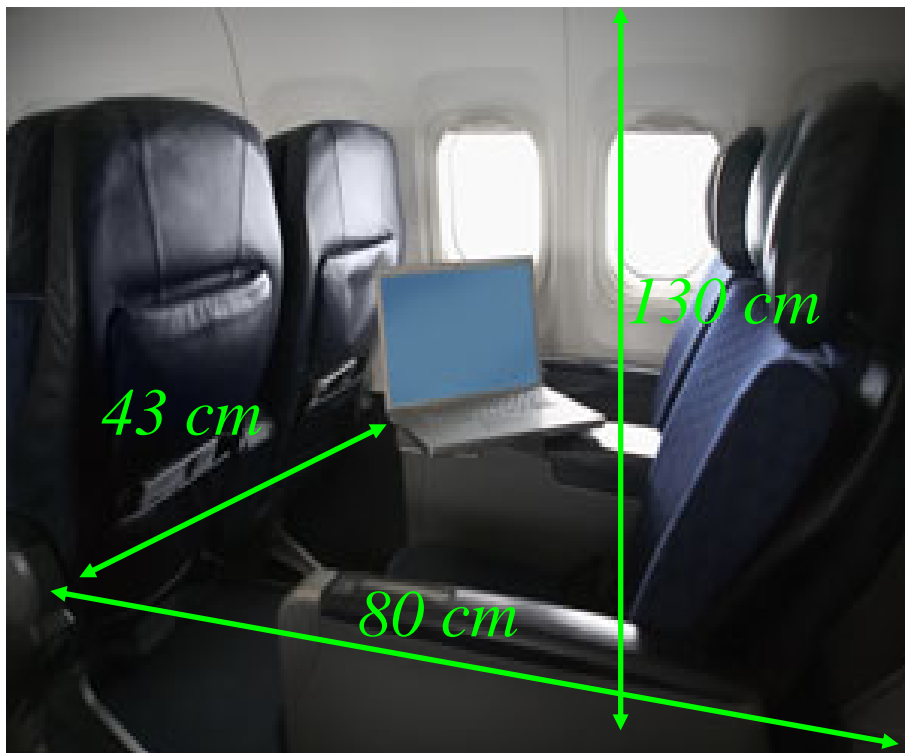

Architecture Definition for On-board Optical Wireless Communications

- With optical wireless, signal is confined to walls, so you need a network to connect the base-station transceivers to a central router/switch. This network could consist of power-lines already feeding the sensors or what brings power to the passenger seat lights.

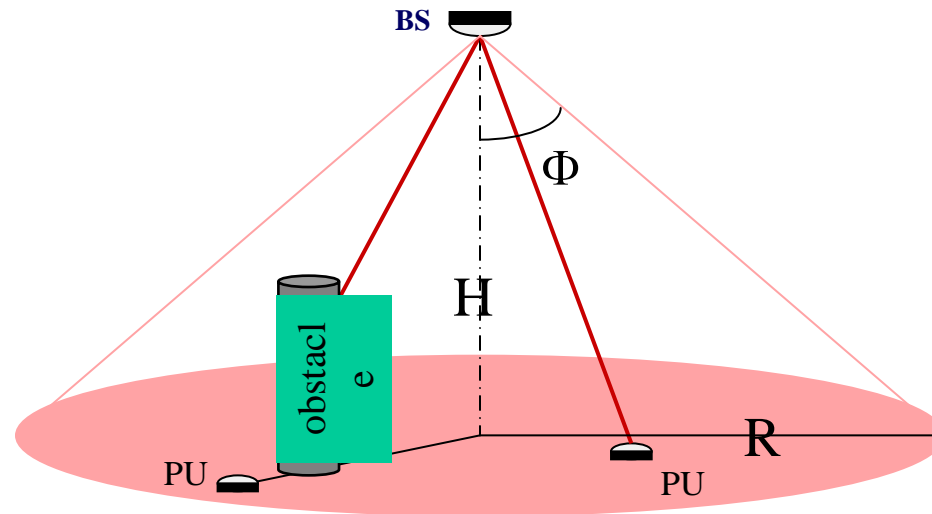

Cellular Architecture for Multimedia Entertainment to Passenger Seat

Simulation Results for Optical Wireless Channel Impulse Response Cellular Architecture; for Multimedia Information to passenger seat

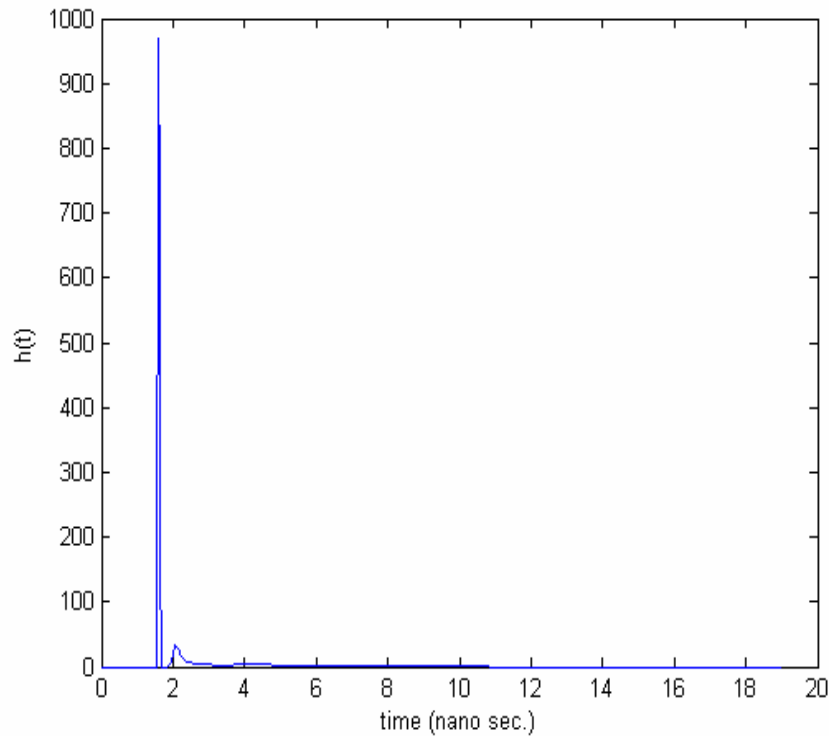

At point (0.5,0.5,0.9)

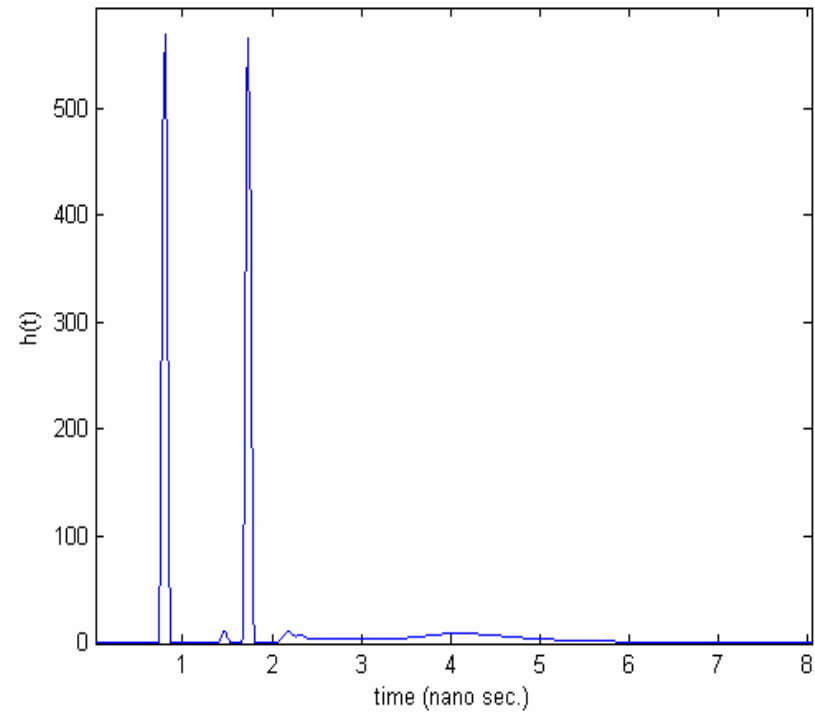

At point (3,2.5,0.9)

Conclusions

- **Optical White LED wireless links offer potential for carrying broadband data in an aircraft cabin.**
- **Designer can guarantee a uniform illumination as well as very high-quality communication links.**
- **Simulations show these systems offer a very high data rate for multimedia data networking.**
- **Power-lines can offer relatively high transmission capacity values.**
- **Consequently, integration of these two techniques will have a great impact as a novel high-capacity transmission system for indoor wireless networking.**