

# *Data Link Messaging Standards for NextGen Data Communications*

*Chris Collings  
Harris Corporation*

# Standards Bodies



**AEEC**



- FANS 1/A+
  - Safety and Performance Standard: DO-306/ED-122
  - Interoperability Standard: DO-258A/ED-100A
- ATN Baseline 1
  - Safety and Performance Standard: DO-290/ED-120
  - Interoperability Standard: DO-280B/ED-110B
  - FANS 1/A Accommodation Standard: DO-305/ED-154
- AEEC 623 Based Standards
  - ARINC 623
  - ED-85A
  - ED-89A

## Interop Overview (ATN & FANS)

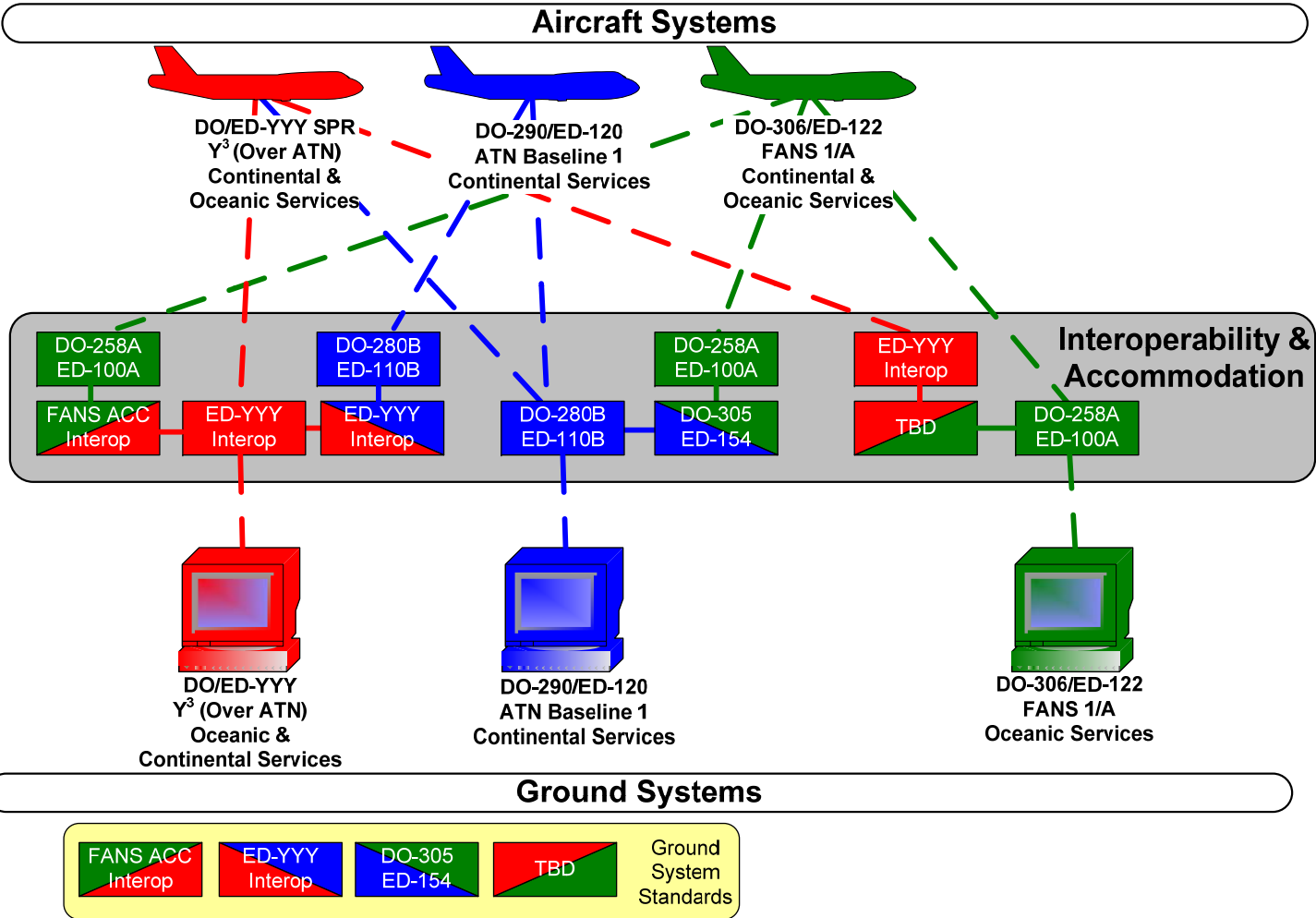

- Context Management – CM
- Controller Pilot Data Link Communications – CPDLC
- Automatic Dependent Surveillance-Contract – ADS-C
- Flight Information System – FIS

- 
- Connection
    - Establishment
    - Maintenance
    - Termination
  
  - ATN Service
    - Data Link Initialization Capability – DLIC
  
  - FANS 1/A Service
    - Airways Facilities Notification – AFN

- 
- Aircraft Communications Management – ACM
  - Aircraft Clearance – ACL
  - Aircraft Microphone Check – AMC
  - Departure Clearance – DCL
  - Digital TAXI – D-TAXI

- Advanced Services Data Link over ATN
  - Backward compatibility with ATN baseline 1
- Work Package 1 – Completed April 2009
  - Inclusion of all ICAO Doc 4444 Messages
  - Additional CDPLC Messages
  - D-OTIS Service
  - D-TAXI Service
- Work Package 2 – Completed December 2009
  - Services supporting 4D trajectory operations
- Validation Period – Completed December 2011

*RTCA SC-214/EUROCAE WG-78  
Deliverables*

---



- Safety and Performance Standard
- ATN Interoperability Standard
- FANS 1/A Accommodation Standard
  
- Final documents delivered December 2011

# Message Set Capabilities

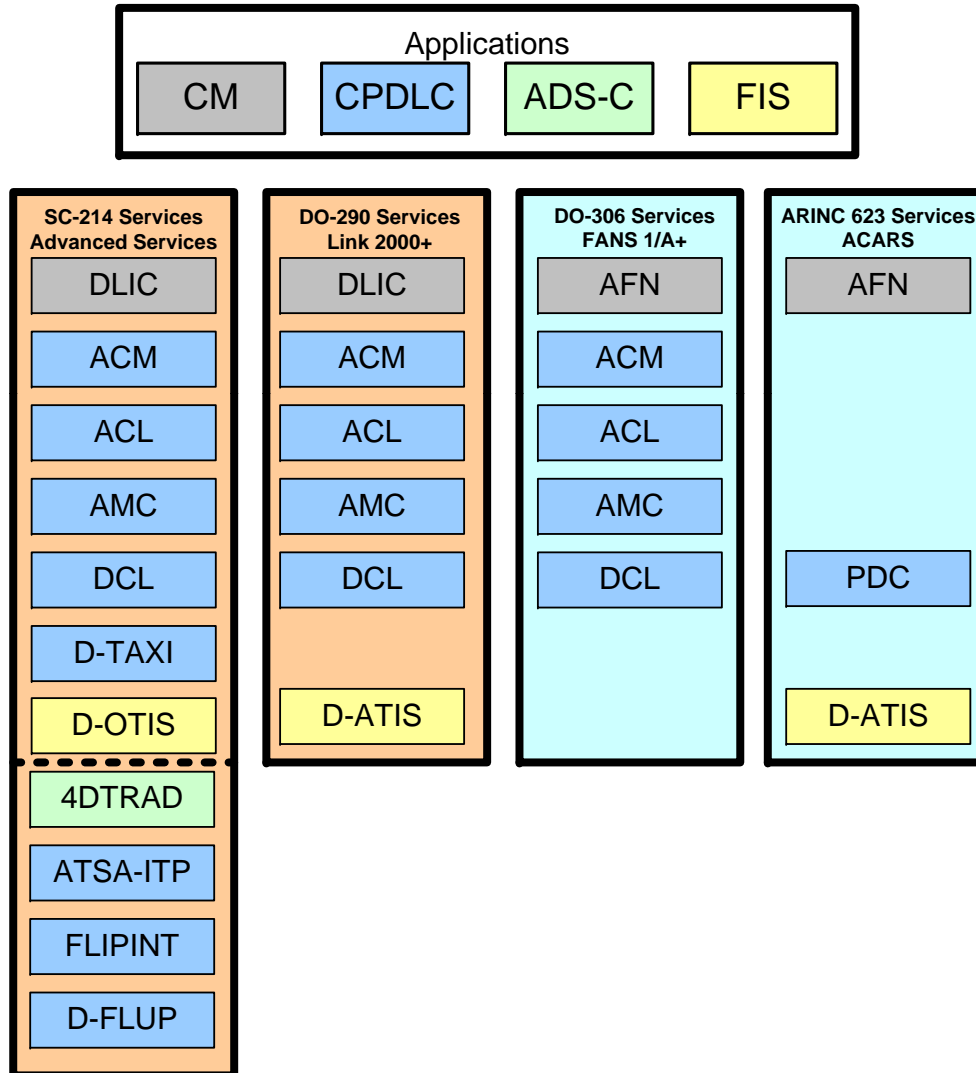

---

*Questions?*